

**ADVANTAGE - 2000+**

**Installation Instructions :**

- # 2540 PSB : Vertical Power Strip Mounting Brackets (pair)
- # 7215 : Power Strip, 15A, 16 pos., Circuit Bkr., 5-15P plug, 49" long
- # 7215-S : Power Strip, 15A, 16 pos., Surge Supp., 5-15P plug, 49" long
- # 7215-15 : Power Strip, 15A, 16 pos., Circuit Bkr., Twist lock L5-15P plug, 49" long
- # 7215-20 : Power Strip, 20A, 16 pos., Circuit Bkr., Twist lock L5-20P plug, 49" long
- # 7218 : Power Strip, 15A, 8 pos., Circuit Bkr., 5-15P plug, 49" long
- # 7222-M : Power Strip, 15A, 6 pos., 18" long
- # 7226-M : Power Strip, 15A, 12 pos., 36" long

**Power Strip Mounting - Frame Uprights :**

*Install vertical power strip mounting brackets (# 2540-PSB) to the frame uprights using standard screws at the locations shown. Pass the mounting slots on the back of the power strip over the welded screw heads on the brackets and push firmly down to lock into place.*

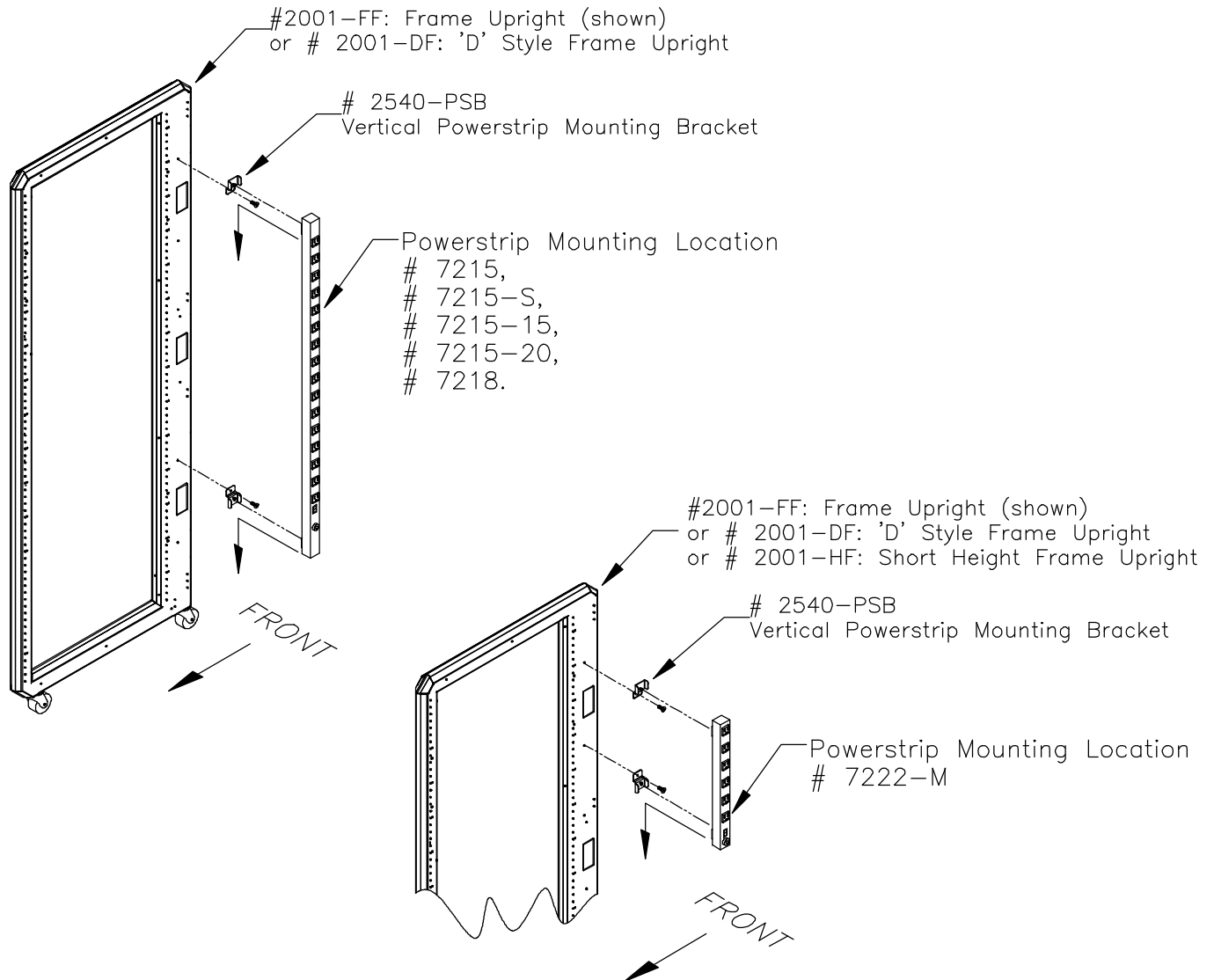

**Power Strip Mounting - Horizontal Cable Management :**

Once the horizontal cable management (26", 50" or 72" nominal width) is mounted to its respective width shelf you can now mount the power strip. Having the cable management previously installed eases the installation of the power strip.

Pass the welded screw heads in the bottom of the cable management through the mounting slots on the back of the power strip and slide firmly to the left or right until seated.

Reference sketch below and use chart to choose the correct power strip with the version of the horizontal cable management being used.

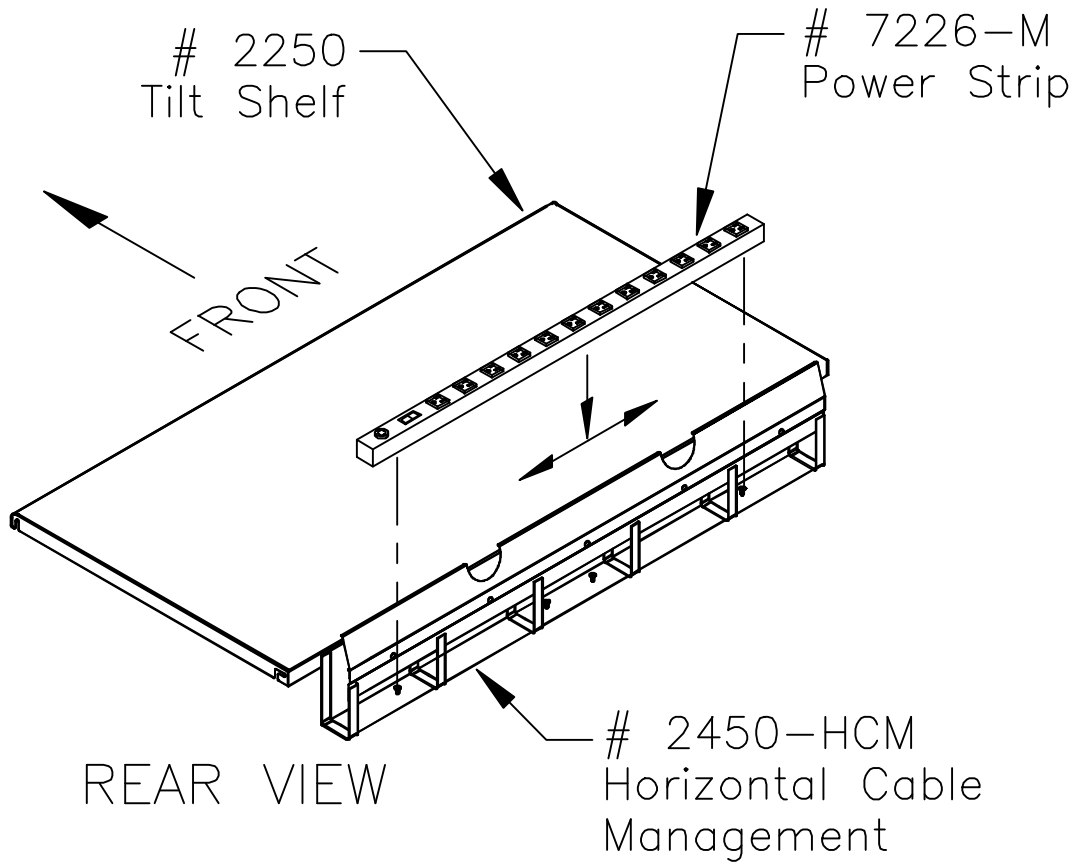

#7226-M Power Strip Mounting (shown)

<u>Horizontal Cable Management</u>		<u>Power Strip to use.</u>
# 2426-HCM	-	#7222-M
# 2450-HCM	- options	#7226-M, # 7222-M
# 2472-HCM	- options	#7215, #7215-S, #7215-15, #7215-20, #7218

**Power Strip Mounting: - Floor Mount Double Wide Tower Shelves :**  
**- Single Tower Sliding Shelves w/ Cable Management Bar:**

After the shelf assembly (either floor mount double wide tower shelves (#22xx-TCx), or single tower sliding shelves (#22xx-TSx) ) has been installed the power strip can now be mounted. Pass the welded screw heads, that are on top of the cable rings, through the mounting slots on the back of the power strip and slide firmly to the left or right until seated.

Reference sketches and charts on the following page to choose the correct power strip with the version of sliding shelf type being used.

**FLOOR MOUNT SLIDING DOUBLE WIDE TOWER SHELVES**

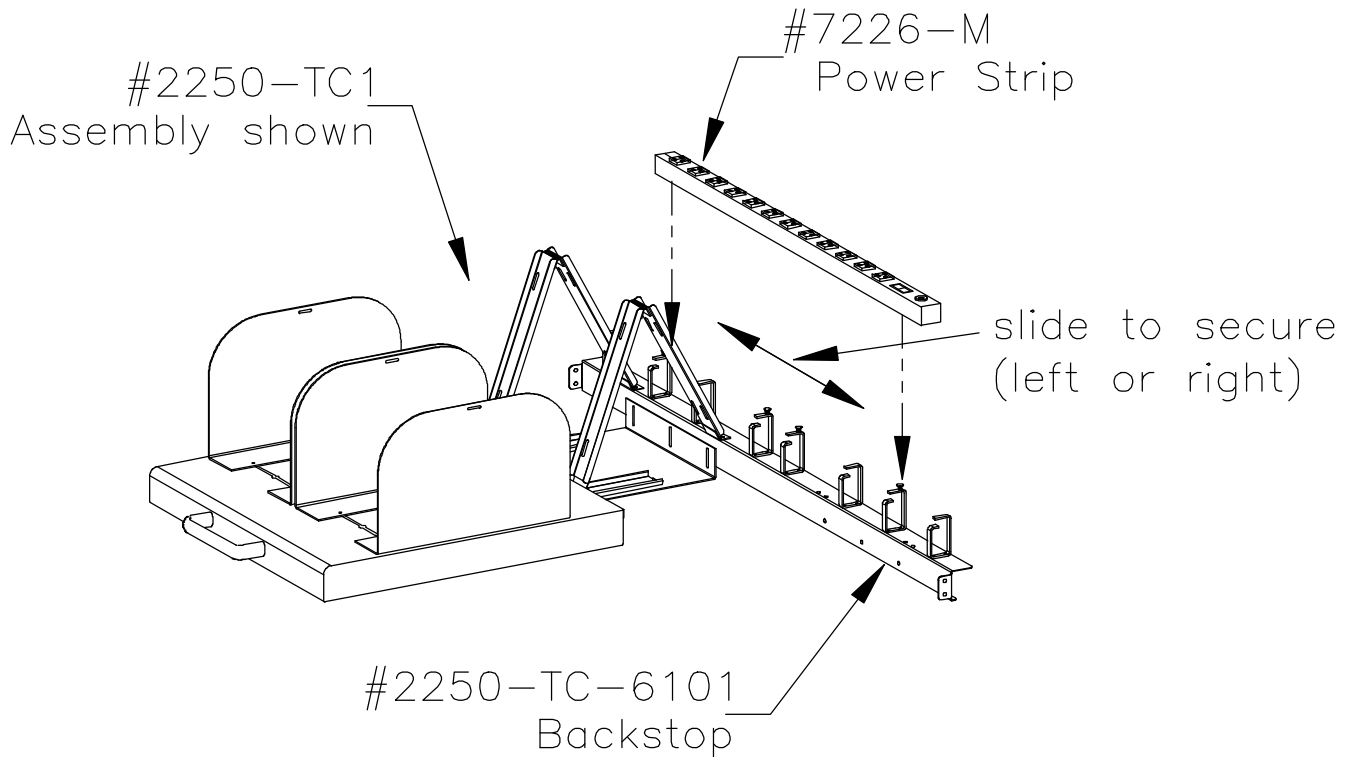

<u>Floor Mount Sliding Shelves</u>	<u>Power Strip to use.</u>
<u># 2226-TC1</u>	<u>- #7222-M</u>
<u># 2250-TC1,-TC2</u>	<u>- options: #7226-M, # 7222-M</u>
<u># 2272-TC1,-TC2,-TC3</u>	<u>- options: #7215, #7215-S, #7215-15, #7215-20, #7218</u>

**SLIDING TOWER SHELVES**

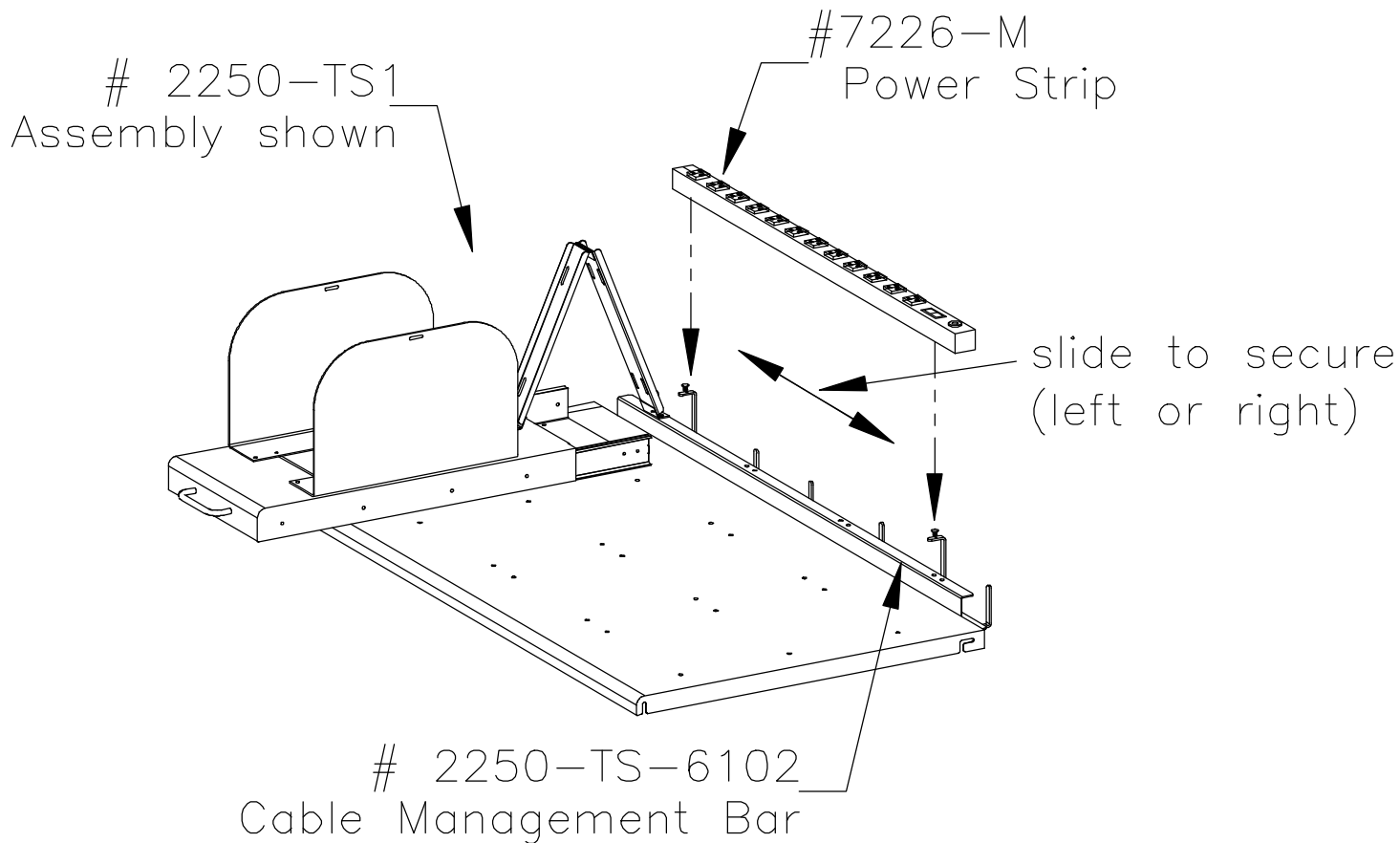

<u>Single Tower Sliding Shelves</u>	<u>Power Strip to use.</u>
# 2226-TS1,-TS2 -	#7222-M
# 2250-TS1,-TS2,-TS3,-TS4 -	options: #7226-M
# 2272-TS1,-TS2,-TS3,-TS4,-TS5,-TS6 -	options: #7215, #7215-S, #7215-15, #7215-20, #7218