

# ADVANTAGE - 2000+

## Installation Instructions :

# GL 2026-C06 : 78”H x 31.5”W x 31.5”D Enclosure  
w/ 19” E.I.A. Mounting (70.5” H - 40 units)

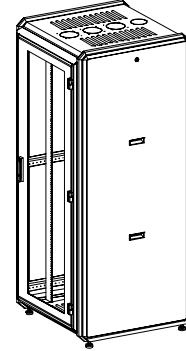

### PARTS LIST: # GL 2026-C06

<u>Item No.</u>	<u>Qty.</u>	<u>Description</u>
1	2	# 2001-FF: Frame Upright Full Height
2	2	# 2626-DJ: 26” wide Door Jamb Full Height
3	2	# 2626-02: 26” wide Plexiglass Door
4	2	# 2010-FFE*(L): Exterior Side Panel Full Height
* w/ or w.o./Lock		
5	1	# 2626-B: 26” wide Enclosure Bottom w/ Cable Access Knockout
6	1	# 2626-T: 26” wide Enclosure Top w/ 3-fan & Cable Access Knockouts
7	6	# 2626-HB: Mounting Bracket for 19” & 23” E.I.A. / 23” Standard spacing
8	2	# 7205-EIA: 19” E.I.A. Mounting Rail - pair (70.5” H - 40 units)

Optional Mounting Rails : # 7205-1112 : 19” E.I.A. (35” H - 20 units)  
 # 7205-1113 : 19” E.I.A. (22.75” H - 13 units)  
 # 7205-23E : 23” E.I.A. (70.5” H - 40 units)  
 # 7205-23 : 23” mtg. 1” spacing (70.5” H )  
 # 7205-2112 : 23” E.I.A. (35” H - 20 units)  
 # 7205-2212 : 23” mtg. 1” spacing (35” H )  
 # 7205-2113 : 23” E.I.A. (22.75” H - 13 units)  
 # 7205-2213 : 23” mtg. 1” spacing (22.75” H )

NOTE: 24” E.I.A. mounting can be achieved by using 23” mounting rails with optional horizontal mounting bracket # 2626-HD24.

STEP (1): Install leveling glides (height adjustment 1” to 2.5”) or locking casters to the threaded holes in the bottom of the frame uprights. Thread casters all the way into the frame uprights.

STEP (2): Start 12 standard screws to the inside edge of each frame upright (#2001-FF) at the locations shown. The two screws at the top and at the bottom receive 1/16” thk. nylon spacers as shown. Leave approximate 3/16” of threads exposed for mounting components.

STEP (3): Mount the enclosure bottom (#2626-B) onto the four screws with the nylon spacer between the frame upright and the outside edges of the bottom, with the cable access knockout in the rear and the mounting edges facing up. Pass the four screw heads through the slots in the enclosure bottom. Install a screw into frame upright through the center holes of the enclosure bottom (#2626-B) to lock into place. Do not tighten screws for enclosure bottom at this time.

STEP (4): Install a 26” wide full height door jamb (#2626-DJ) onto the rear of the enclosure by sliding the mounting tab screw slots over the eight screws previously started on the rear of the frame uprights. The door jamb is configured with the hinges on the right side prior to shipping. Opposite hand hinged is obtained by rotating the door jamb & rotating the swing handle. Once the door jamb is in place, install two screws per corner into the frame uprights through the holes in the door jamb. Tighten all screws for the rear door jamb at this time.

NOTE: DO NOT TIGHTEN TOP & BOTTOM MOUNTING SCREWS UNTIL BOTH DOOR JAMBS ARE MOUNTED.  
(for ease of assembly)

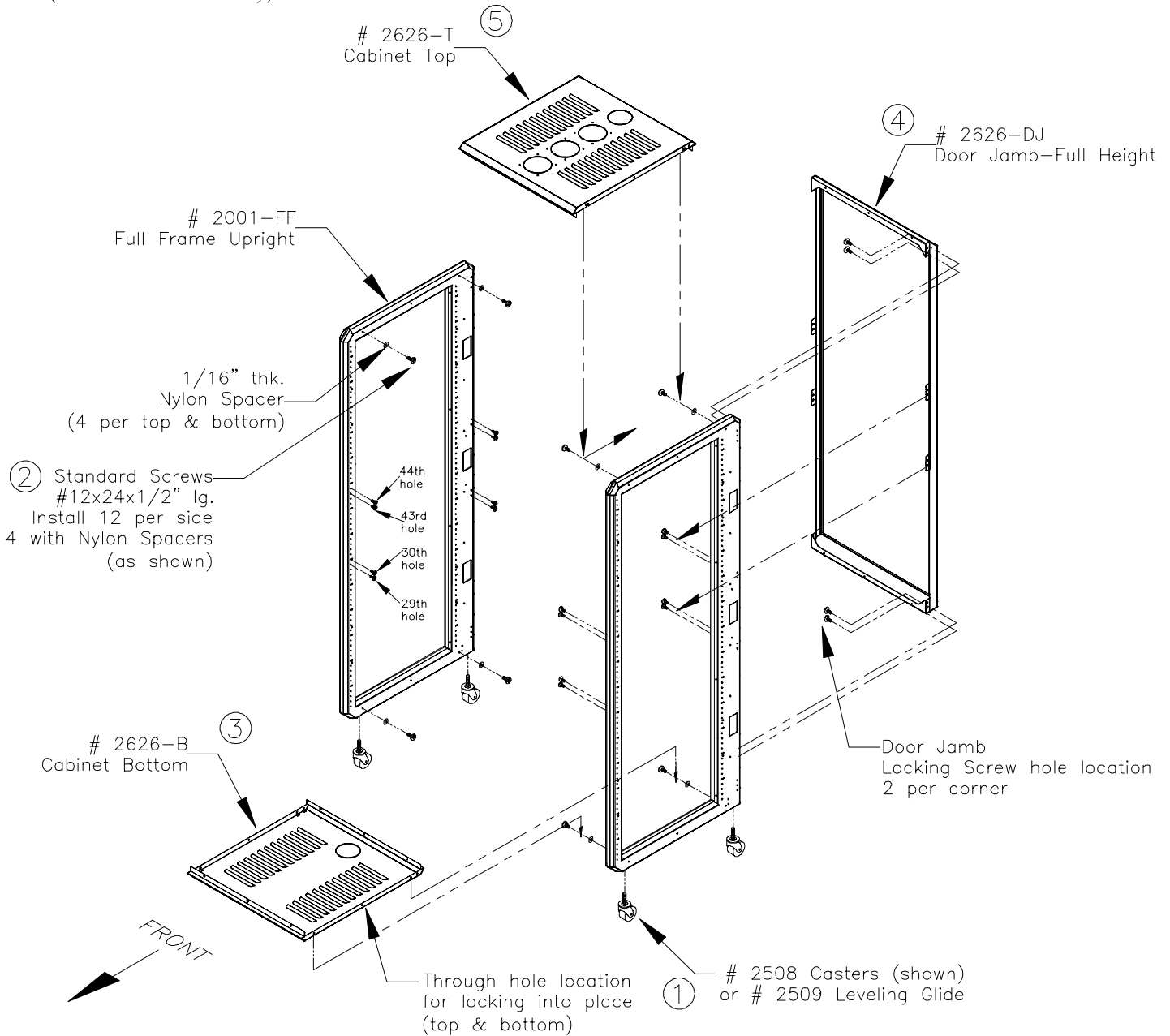

***STEP (5):*** Mount the enclosure top (#2626-T) onto the four screws with the nylon spacer between the frame uprights and outside edges of the top, with the cable access knockout in the rear and the mounting edges facing down. Pass the four screw heads into the mounting slots in the side edges of the top and push towards the rear until seated firmly. Install a screw into the frame upright through the center screw holes of the enclosure top (#2626-T) to lock into place. Do not tighten these screws at this time.

**STEP (6-A):** Install a 26" wide full height door jamb onto the front of the cabinet by repeating STEP (4). Install 6 screws per top and 6 screws per bottom into the threaded holes on both door jambs through the slots located at the front and rear edges of the top and bottom.

**STEP (6-B): TIGHTEN ALL SCREWS FOR ENCLOSURE TOPS, BOTTOMS & DOOR JAMBS AT THIS TIME.**

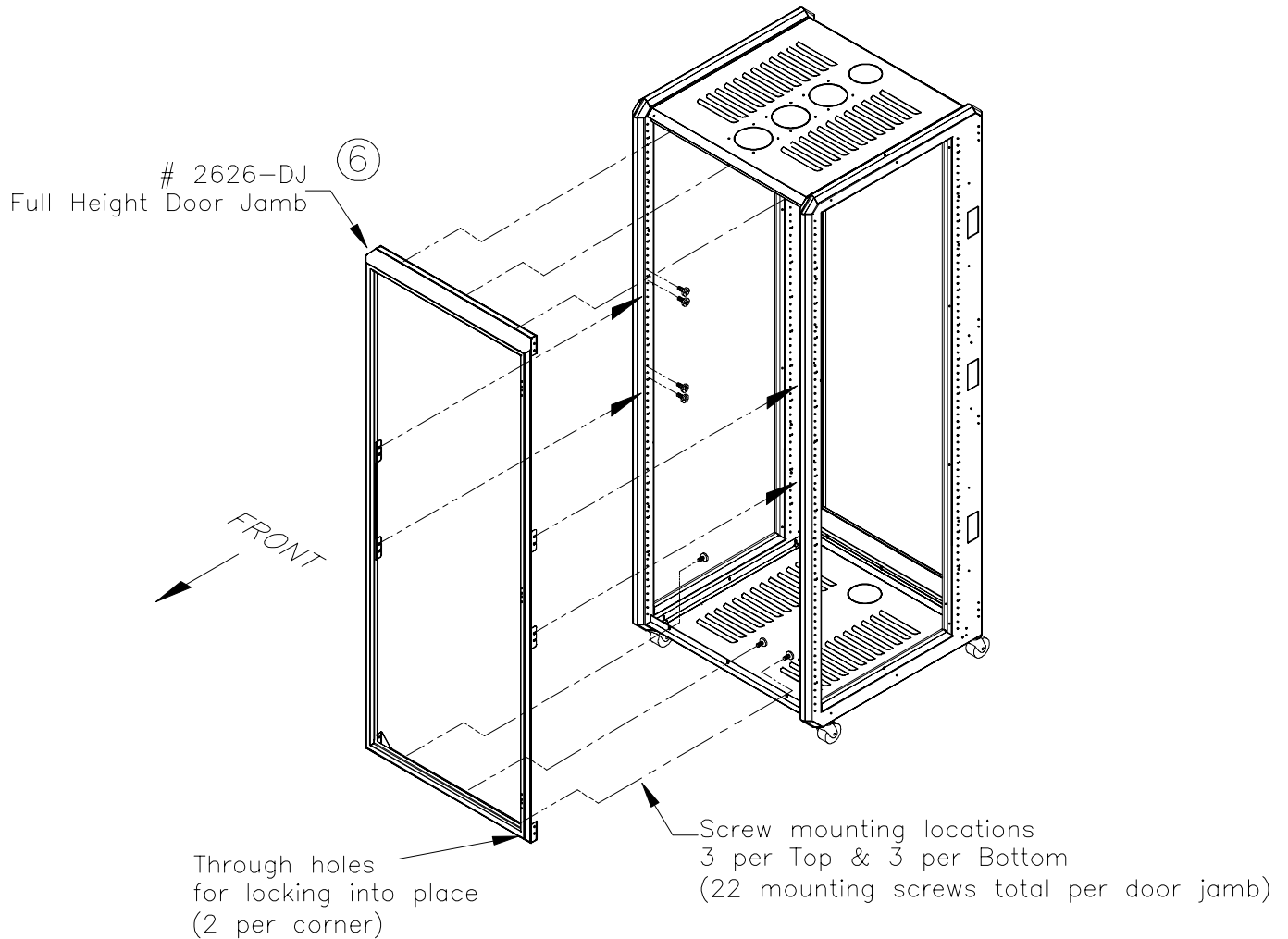

***STEP (7):*** Mounting enclosure doors to door jambs is done by removing the top hinge on the door. Hang the door on the two pivot pins that are mounted on the door jamb. With the door open place the hinge that was removed onto the remaining pivot pin and install the two black #10-32 screws into the hinge through the holes in the door. Do this for both doors. Once this is done the door is captive.

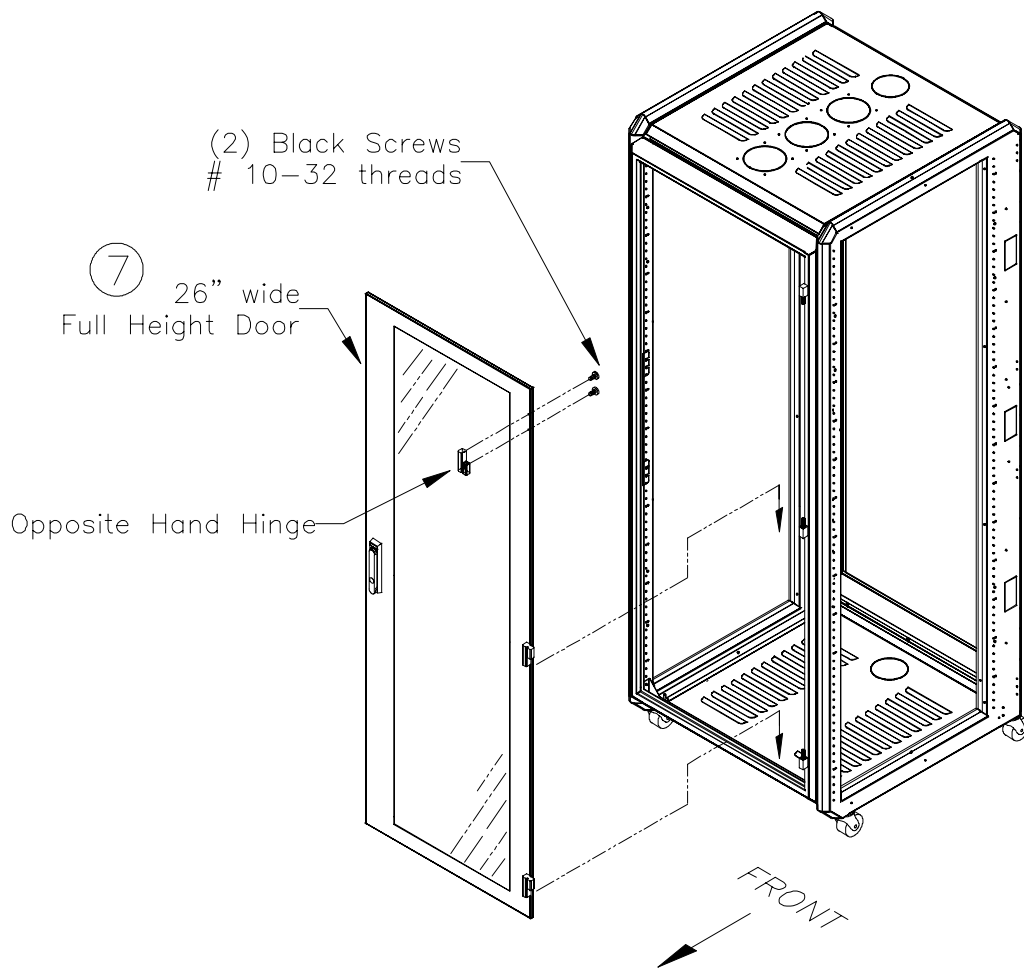

**STEP (8):** Install 6 screws with nylon hat spacers provided at the locations shown on the outside edge of the frame uprights. See detail. Remove the cable throughway grommet covers on the frame upright on the same side that the exterior side panel is being mounted. Mount the exterior side panel to the assembly by aligning the screw slots on the side panel to the screws and sliding it down until seated firmly on the screws. If using locking exterior side panels, remove the lock nut from the lock assembly then insert the lock assembly through the side panel hole (shown). Slide the lock nut over the locking pawl and tighten against the inside of the side panel. When installing the lock assembly be sure that the locking pawl will be able to turn 90 degrees from being horizontal (unlocked position) to facing up. (locked position - shown).

**Warning:** Do not remove the key from the locking barrel if or when the locking pawl is removed!

**NOTE :** If networking enclosures together repeat steps 1 through 7 using the outside edge of the existing upright frame to be the inside edge of the new enclosure.

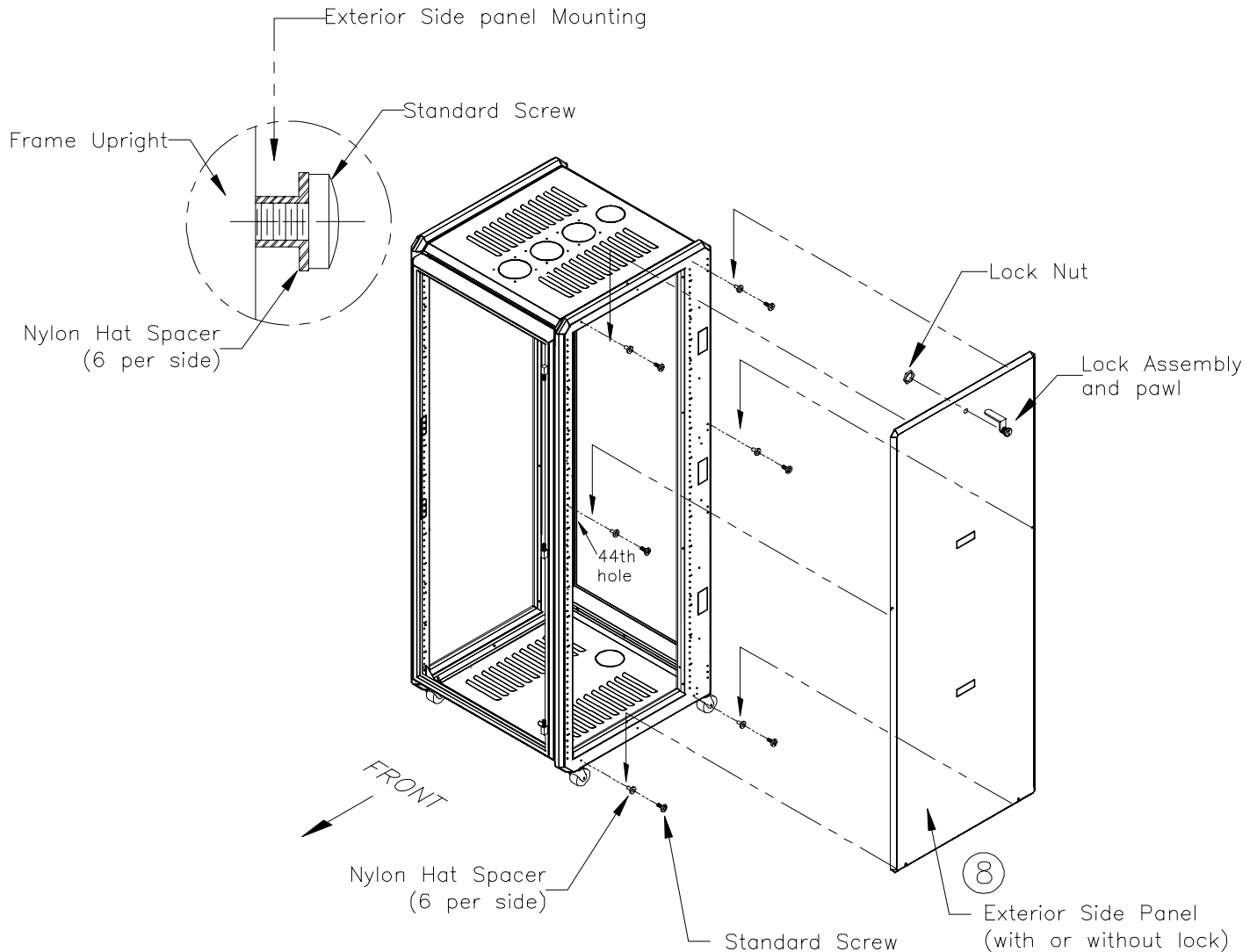

***STEP (9): Mounting the horizontal brackets and rails to the inside edge of the frame uprights is done by installing four screws per bracket with the through holes toward the front of the cabinet. The top and bottom bracket should be positioned in the upper and bottom most holes on the frame upright when using a full length rail. The brackets can be adjusted vertically in 1" increments with the middle brackets centered. Mount the rail to the bracket using the through holes at 1" increments at the depth location desired.***

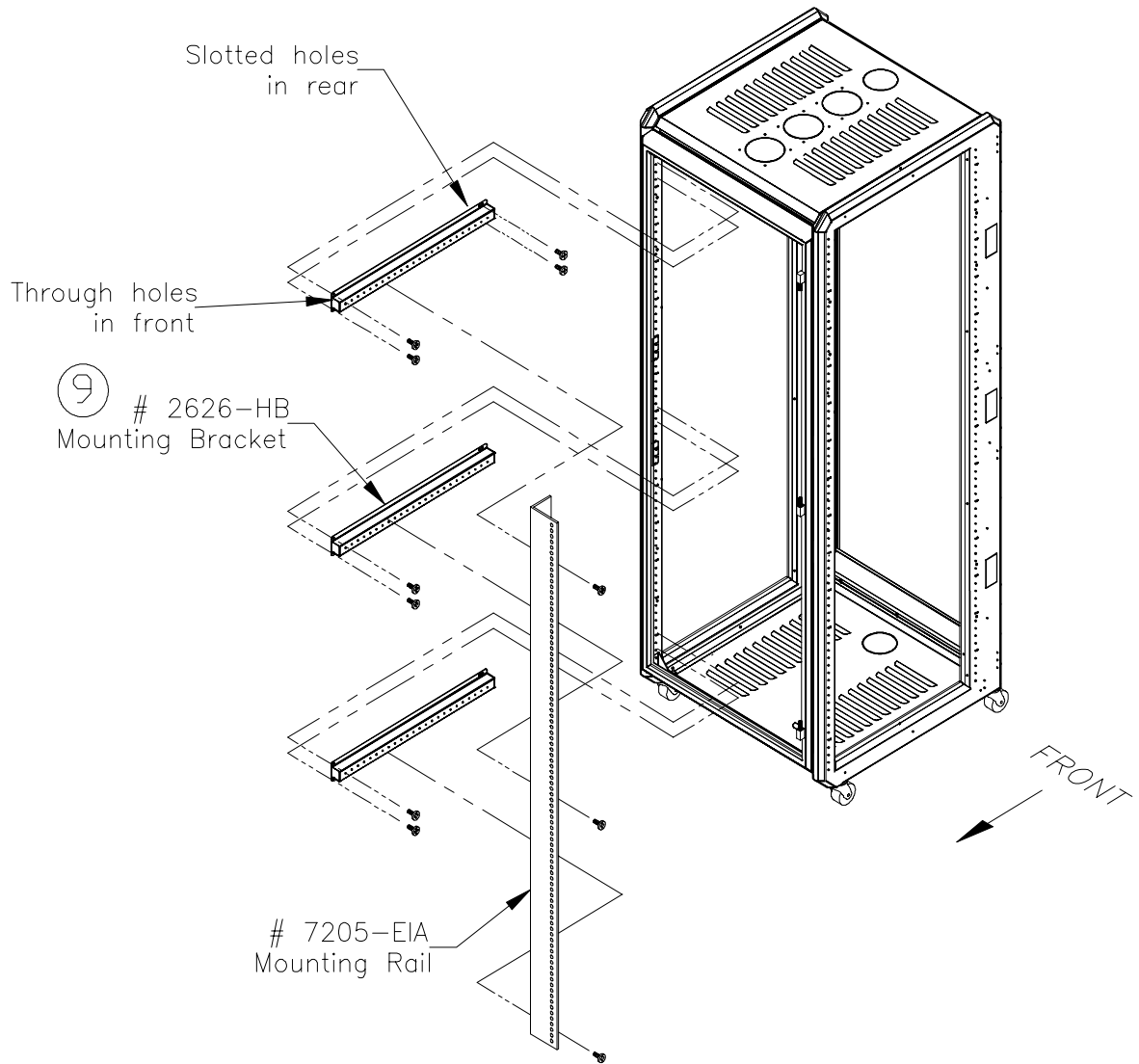

*The doors and side panels are removed for clarity.*

**THIGHTEN ALL SCREWS BEFORE LOADING WITH EQUIPMENT!**

Technical Assistance : (814) 734 - 7303

Instruction # 26WDCAB

REV. # 2 - 6/17/98