

ADVANTAGE - 2000+

Installation Instructions:

- # 2226-DLA : 26" wide Worksurface - Laminated Wood - 4 Point Mounting
- # 2250-DLA : 50" wide Worksurface - Laminated Wood - 4 Point Mounting
- # 2272-DLA : 72" wide Worksurface - Laminated Wood - 4 Point Mounting

These shelves provide an extra 6" of work surface depth as compared to our standard 4 point mounting shelves.

STEP (1): Installing Brackets to Worksurfaces:

*Using four (4) Standard Screws (#12-24x1/2"lg.) per bracket, install the screws through the bracket and into the three unmarked tapped holes in the underside of the Worksurface. Use the appropriate bracket for the correct Worksurface. **TIGHTEN** all eight screws.*

REFER TO SKETCH - 1:

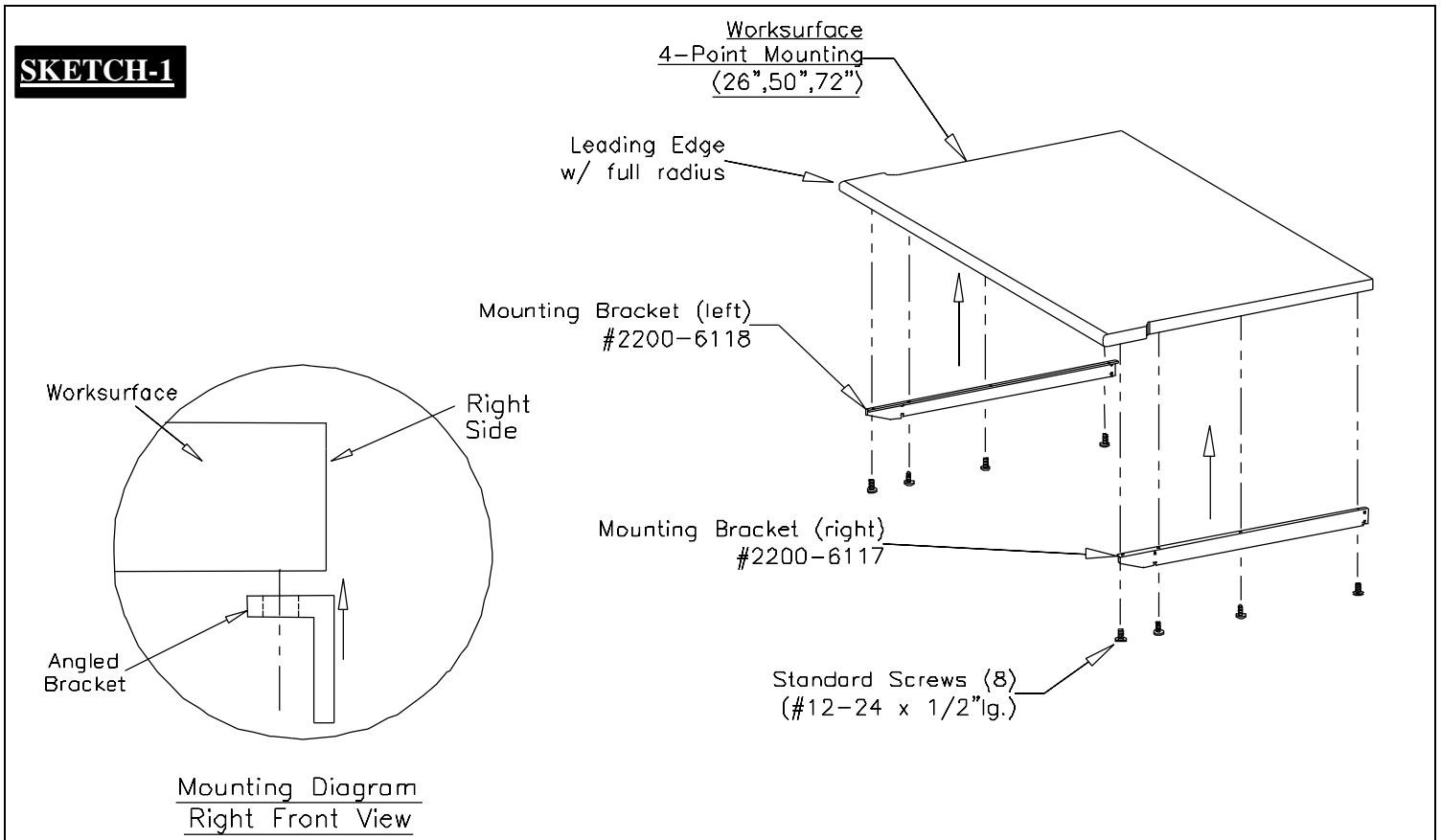

STEP (2): Mounting the Worksurfaces to the Frame Uprights:

With the Frame Uprights and Braces having been previously assembled with the corresponding Worksurface width (26", 50", 72") choose the desired height for your Worksurface by placing four (4) Standard Screws into the threaded holes in the Frame Uprights as shown. The top surface of the shelf will be approx. 2-1/2" above the screw location. Leave approx. 3/16" of threads exposed. See Mounting Diagram in Sketch-2.

Position the slots in the Mounting Brackets that are installed to the Worksurface, over the screw threads. The Worksurface will rest on the four screws. Install four screws through the round holes in the Mounting Bracket to lock the Worksurface into position.

TIGHTEN ALL EIGHT SCREWS. - REFER TO SKETCH - 2:

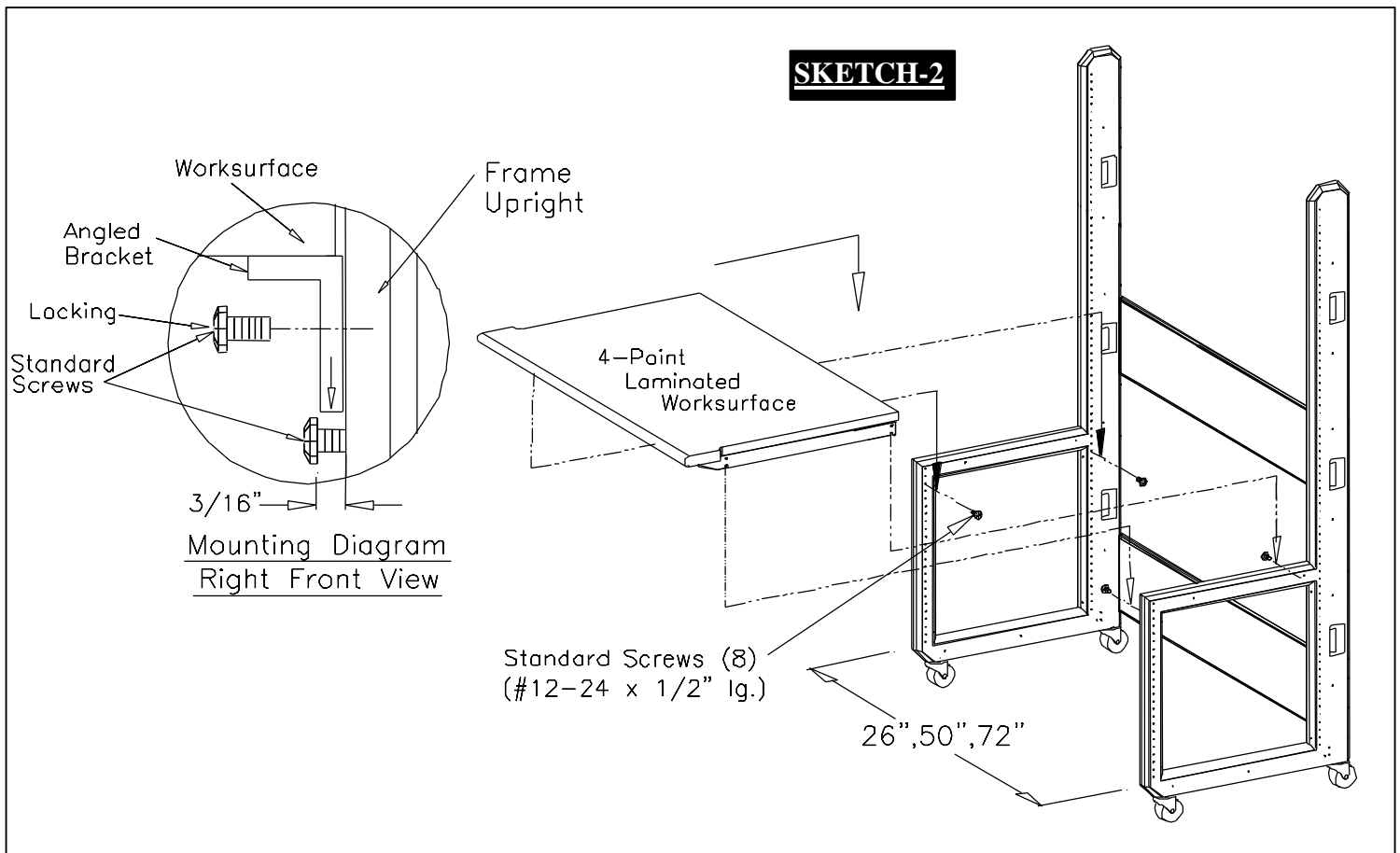

TIGHTEN ALL SCREWS BEFORE LOADING WITH EQUIPMENT!