

Installation Instructions :

2520-19RK : 19" E.I.A. spacing, 5-Units, Underside Shelf Mounting.

2526-19F : 19" E.I.A. spacing, 7-Units, for 26" wide Configurations.

Mounting # 2520-19RK : Underside Shelf Mounting:

The underside shelf mounting version of 19" E.I.A. spacing will mount to the Cantilevered Shelves (except Light Duty Cantilevered Shelves) and Four Point Mounted Shelves & Laminated Worksurfaces. The 19" E.I.A. Vertical Mounting Rails (5U) have a front to rear adjustable mounting range of 14" at 1" increments.

STEP (1): On the underside of the shelf surface there are threaded holes with letter codes next to them. The holes marked 'K' are the holes (four) needed to mount #2520-19RK Hanging Rail Kit. Install two screws into the holes closest to the front of the shelf marked 'K' and are 22.75" apart. Leaving approx. 1/8" of threads exposed.

Note: 26" wide shelves have one mounting position.

50" wide shelves have two side by side mounting positions.

72" wide shelves have three side by side mounting positions.

Install the Mounting Brackets #2520-19RK-6101 by passing the screw heads through the keyed holes in the Mounting Brackets. **Reference Front View in Sketch-1.** Install another screw through the round hole in the rear of the Mounting Bracket.

REFERENCE SKETCH-1.

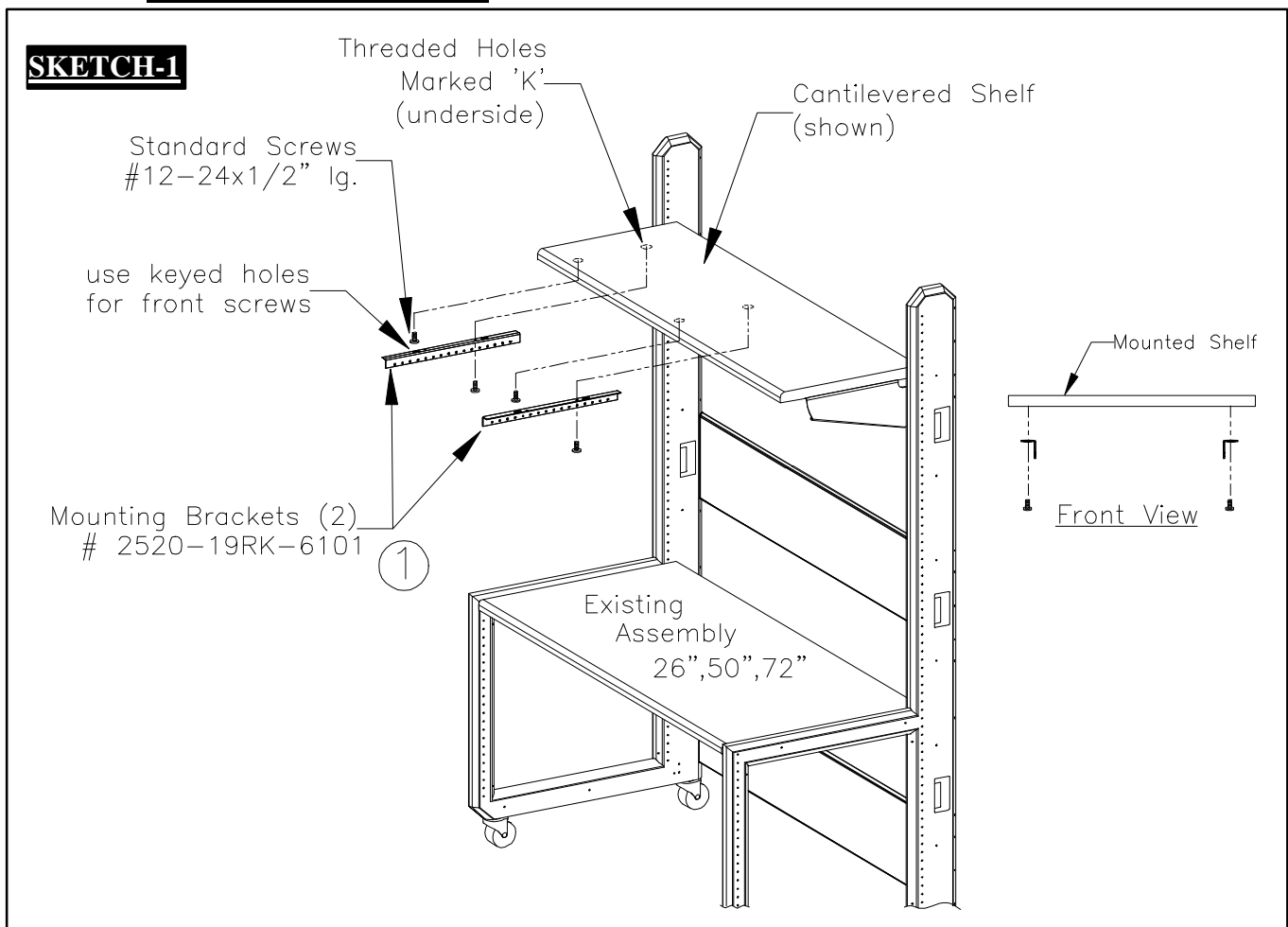

STEP (2): Mount the 19" E.I.A. Rails # 2520-19RK-6103 to the Mounting Brackets previously installed to the shelf. Use two (2) standard screws through the Mounting Bracket holes and into the threaded holes at the end of the Rail. The 19" E.I.A. Vertical Mounting Rails (5U) have a front to rear adjustable mounting range of 14" at 1" increments.

STEP (3): Mount the Horizontal Bracket #2520-19RK-6102 to the inside edge of the Rails using two (2) standard screws per end. The screws pass through the round holes in the Horizontal Brackets and into the threaded holes at the bottom of the Rails.

TIGHTEN ALL SCREWS BEFORE LOADING WITH EQUIPMENT.

REFERENCE SKETCH-2.

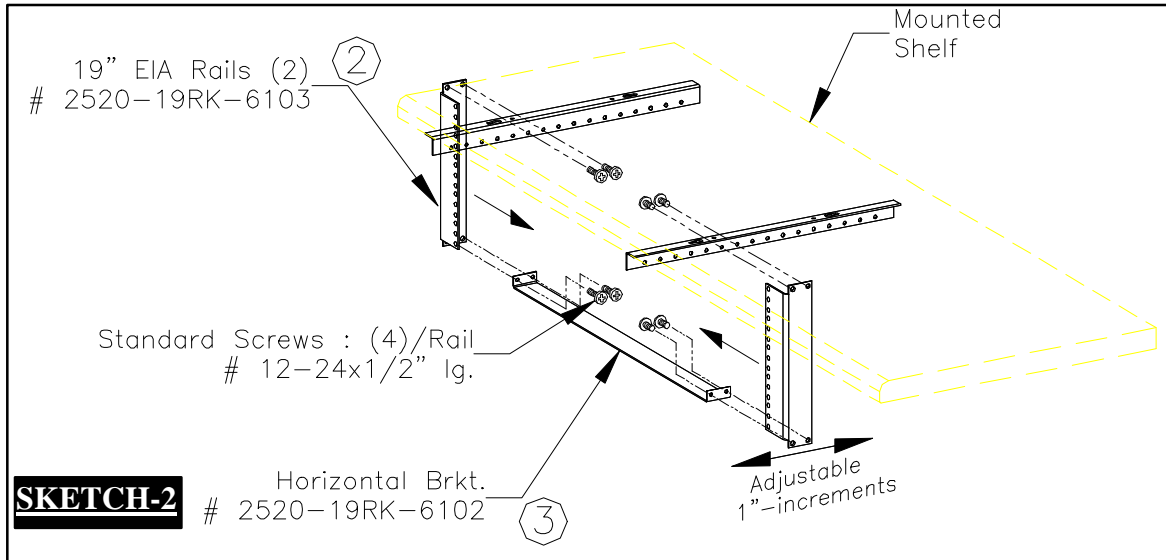

Mounting # 2526-19F : 19" E.I.A. Conversion for 26" wide Configuration:

STEP (1): Install two (2) standard screws five inches apart vertically in the threaded holes on the inside edge of each Frame Upright in a 26" wide assembly. Leave approx. 3/16" of threads exposed.

STEP (2): Slide the Mounting Rails # 2526-19F-6101 over the screw heads using the slots in the rails and then let it slide down until seated firmly. Install three (3) screws into the Frame Uprights through the remaining round holes in each Rail. **TIGHTEN ALL SCREWS BEFORE LOADING.**

REFERENCE SKETCH-3.

