

**ADVANTAGE - 2000+**

**Installation Instructions :**

# 2575 : Hanging Filing Cabinet w/ Three 5.5" high drawers

# 2585 : Hanging Filing Cabinet w/ One 5.5" high drawer & One 10.5" high drawer

Outside Dimensions : 17" wide x 21 1/2" high x 18 1/2" deep.

**PARTS LIST: # 2575**

<u>Item No.</u>	<u>Component Description</u>	<u>Qty.</u>
1	#2500-6104 : Right Side Panel	1
2	#2500-6105 : Left Side Panel w/ Lock Ass'y.	1
3	#2500-6101 : Top Panel	1
4	#2500-6102 : Bottom Panel	1
5	#2500-6103 : Back Panel.	1
6	#2500-6109 : Drawer : 5 1/2" deep w/ handle & two 16" slides	3
7	Standard Screws : # 12-24 thds. x 1/2"lg.	22
8	Slide Mounting Screws : #8-32 thds. x 1/4" lg.	24

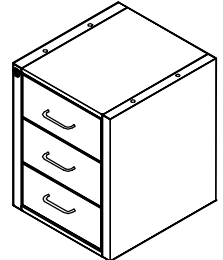

PART No. #2575

**PARTS LIST: # 2585**

<u>Item No.</u>	<u>Component Description</u>	<u>Qty.</u>
1	#2500-6104 : Right Side Panel	1
2	#2500-6105 : Left Side Panel w/ Lock Ass'y.	1
3	#2500-6101 : Top Panel	1
4	#2500-6102 : Bottom Panel	1
5	#2500-6103 : Back Panel	1
6	#2500-6109 :Drawer : 5 1/2" deep w/ handle & two 16" slides	1
7	#2500-6110 : Drawer : 10 1/2"deep w/ handle & two 16" slides	1
8	Standard Screws : # 12-24 thds. x 1/2" lg.	22
9	Slide Mounting Screws : #8-32 thds. x 1/4" lg	16

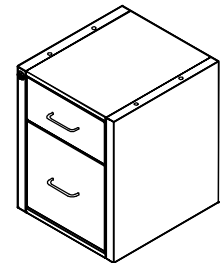

PART No. #2585

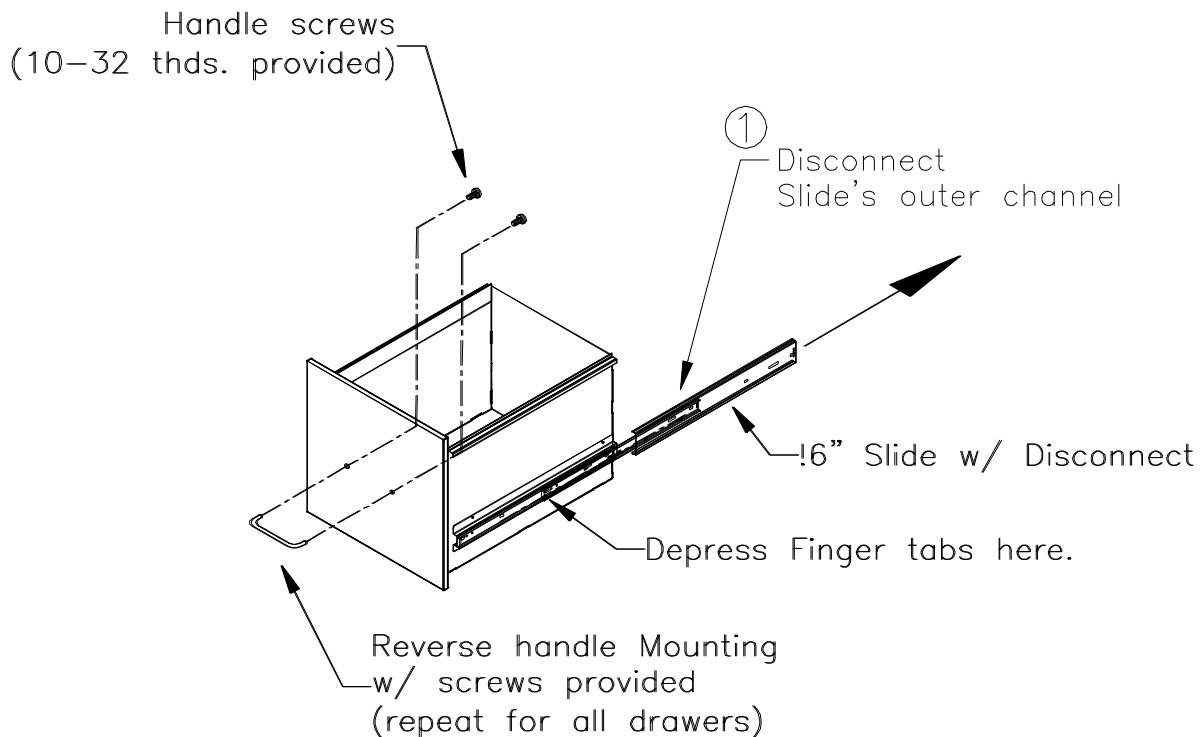

**STEP (1):** Disconnect the outer channel of the slides that are mounted to the drawers. Fully extend the slide. With finger tabs depressed pull outer channel off the mounted inner channel. At this time reverse the handle mounting using the same mounting screws.

**See Diagram on Sheet - 1.**

**STEP (2):** Mount the outer slide channels to the side panels w/ four (#8-32 x 1/4") screws per slide channel (screws provided). Mount the outer channel to the side panels with the intermediate channel sliding out in the same direction as the top keyed hole. Eight screws are provided for each drawer.

**STEP (3):** Install six standard screws (#12-24 x 1/2" lg) into locations shown. Leaving approx. 1/8" of threads exposed to be able to mount the top, bottom & back panels.

**Repeat for Right Side panel (#2500-6104).**

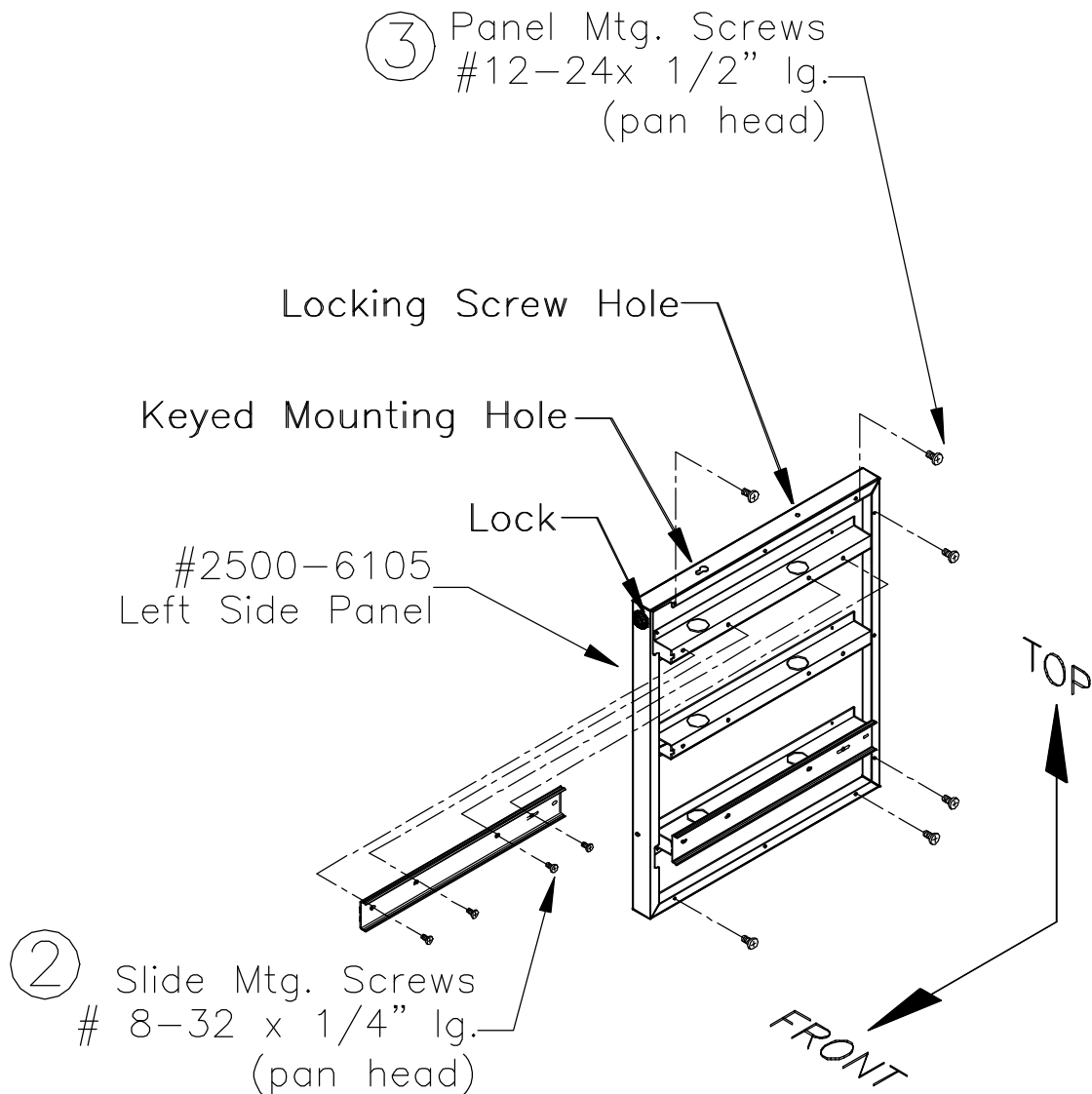

**STEP (4):** Mount the Bottom Panel (#2500-6102) onto the four screws in the side panels and install two screws into the center holes of the bottom panel to lock into place.

**STEP (5):** Mount the Back Panel (#2500-6103) by sliding the four mounting screws slots of the back panel over the four screws on the rear of the side panels. Install two screws into the center holes of the back panel to lock into place.

**STEP (6):** Mount the Top Panel (#2500-6101) onto the four screws in the side panels and install two screws into the center holes of the top panel to lock into place.

**Tighten all 18 screws of the cabinet housing assembly prior to mounting.**

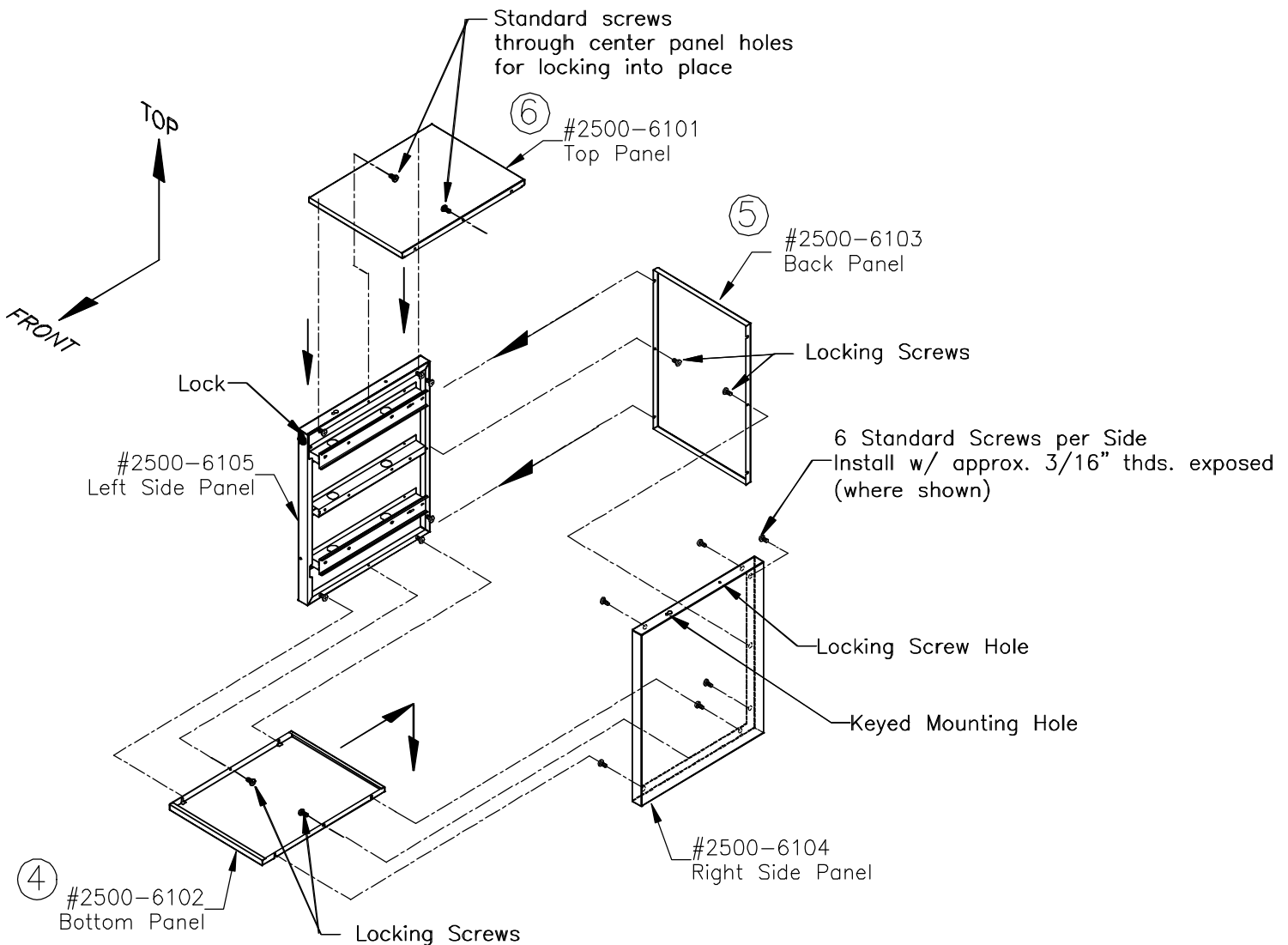

***STEP (7):*** The location of your hanging filing cabinet can be under any 26",50", or 72"wide 4-Point Tilt Shelf; Countertops; or the Peninsula Worksurface. On the underside of the shelf there will be threaded holes with letter codes stamped next to them except Peninsula Worksurface. Locate the holes with the letter code marked 'F' next to them.

***Note:*** 26" wide shelves have one Filing Cabinet mounting position

50" wide shelves have two Filing Cabinet mounting positions

72" wide shelves have four Filing Cabinet mounting positions

Install two standard screws into the holes that are closest to the front of the shelf and are 15.5" apart, leaving approx. 1/8" of threads exposed. Pass the heads of the screws through the keyed mounting holes on the top of the filing cabinet and push back against the cabinet until the screw heads are seated. At this point the cabinet will hang on its own. **IT IS NOT SECURED YET - USE CAUTION.**

Install two screws into the through holes that are at the rear of the filing cabinet to lock into place. Tighten all four mounting screws. To tighten the four mounting screws the screwdriver provided must pass through the holes behind the slide mounting channel in the side panels

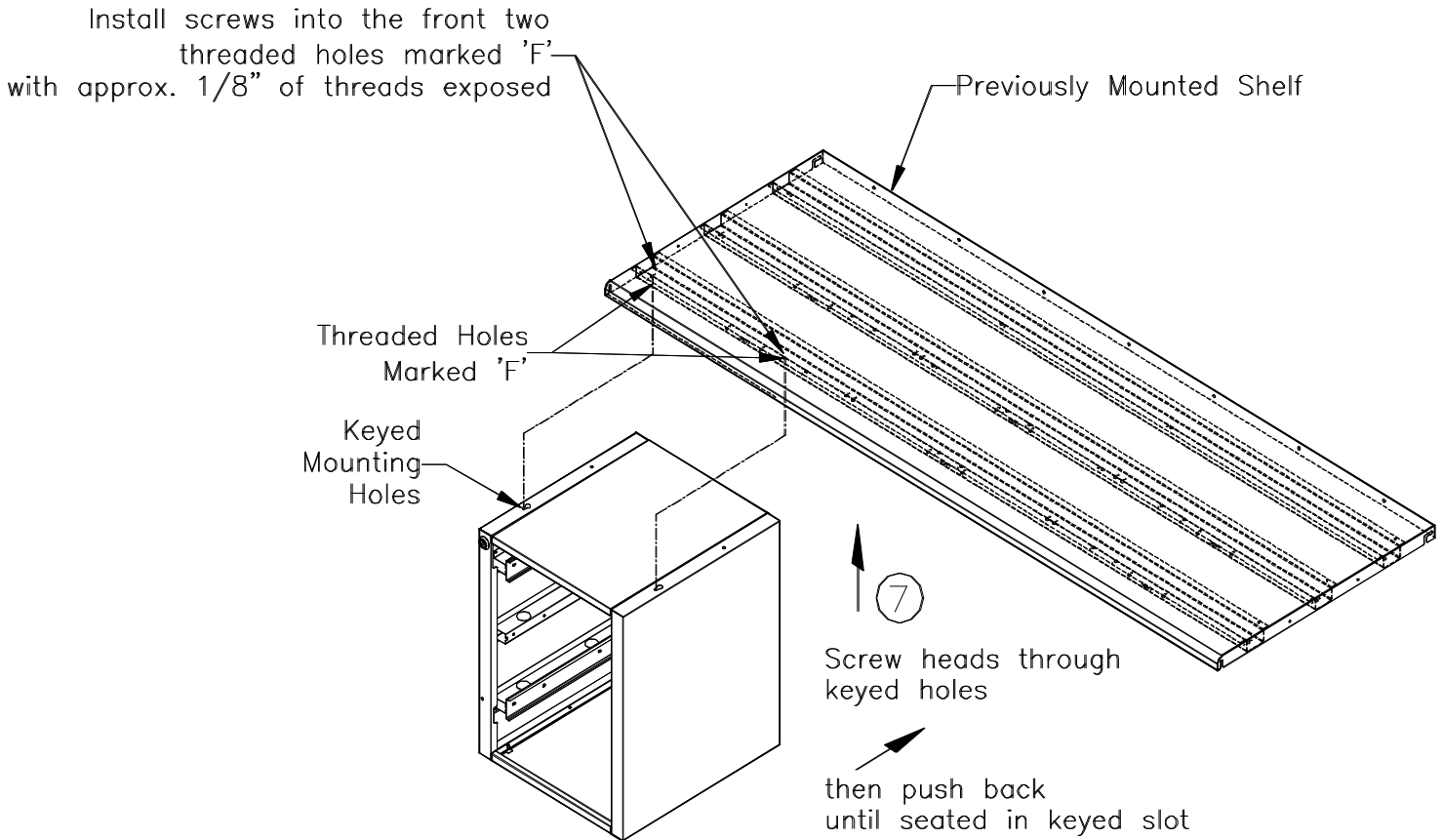

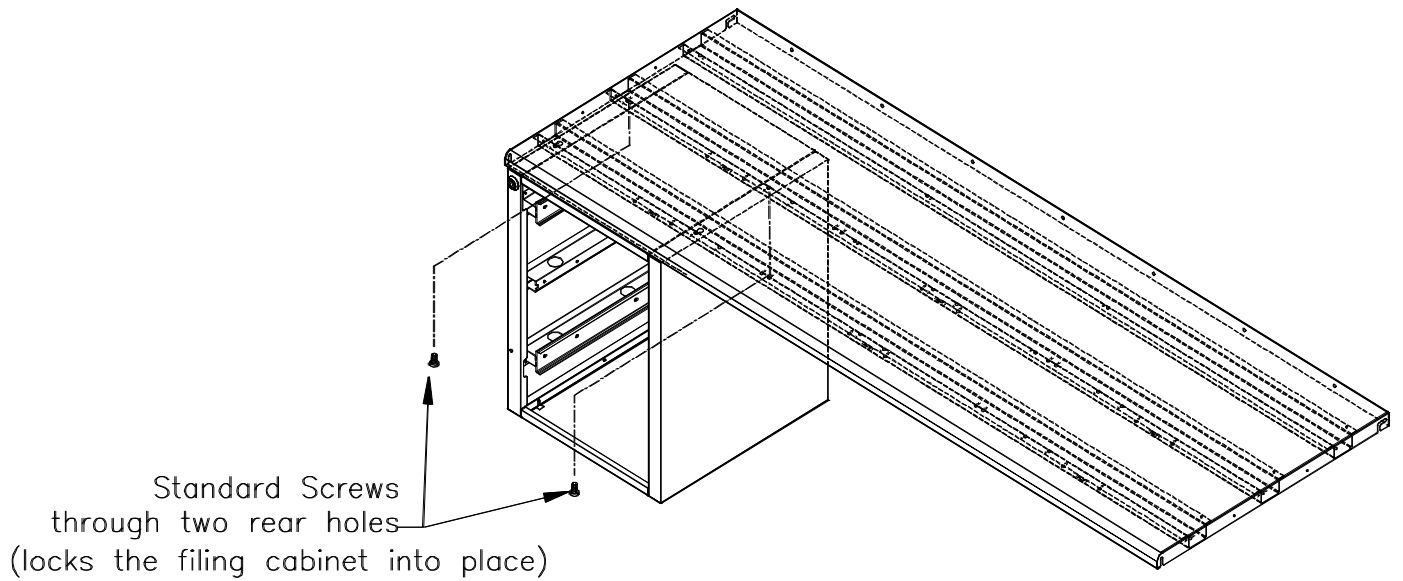

TIGHTEN ALL FOUR MOUNTING SCREWS AT THIS POINT

***STEP (8):*** Install the drawers by aligning the mounted slide channels on the drawer to the slide channels mounted to the side panels and sliding the drawer into the cabinet housing. Push the drawer in completely. The drawer slide will lock together at this time. To disconnect drawer slides, extend fully & depress finger tabs on each slide simultaneously and pull out.

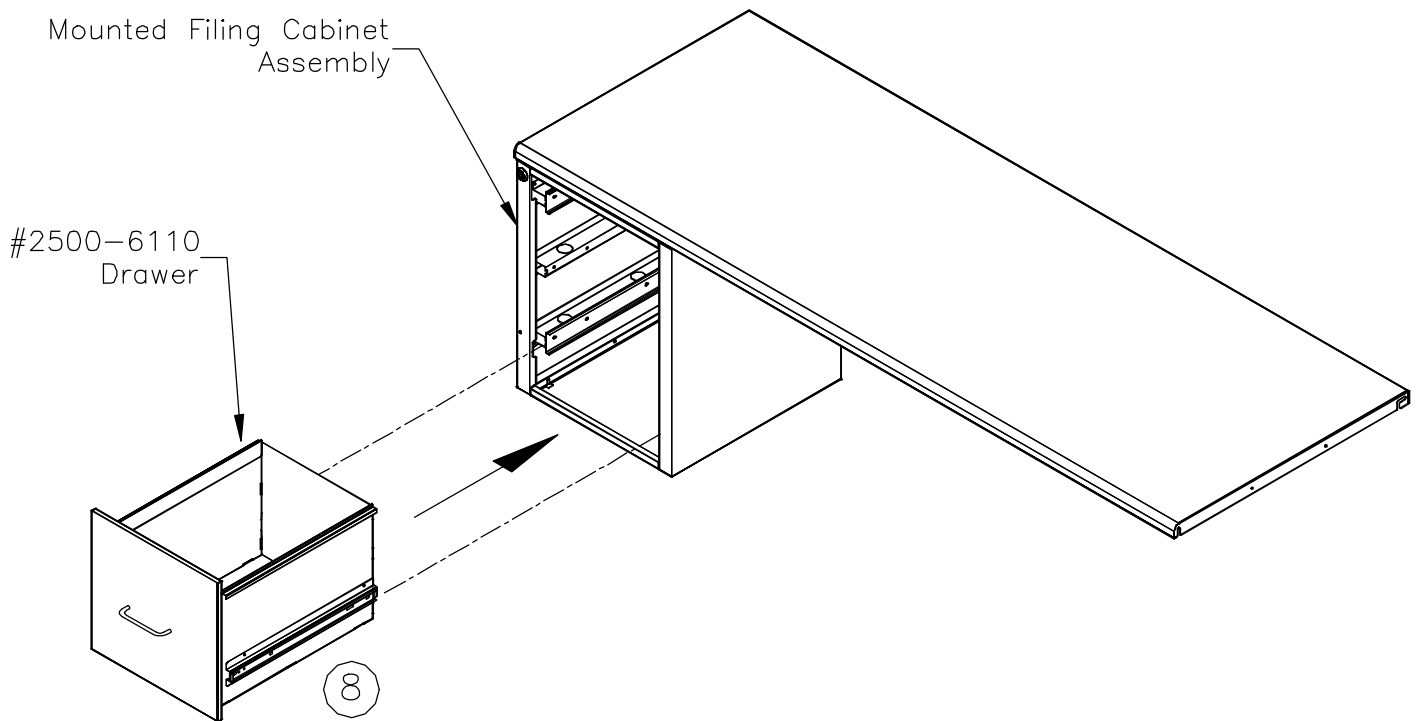

**Step (9): Repeat STEP (8) for the remaining drawers to install them into the filing cabinet assembly.**

**BE SURE TO TIGHTEN ALL SCREWS BEFORE LOADING!**

